



EXACTCAST ADS (EX / EXF)

Silicate-bonded, highly exothermic, fiber-free mini-risers for iron and cast steel



Riser Types & Dimensions

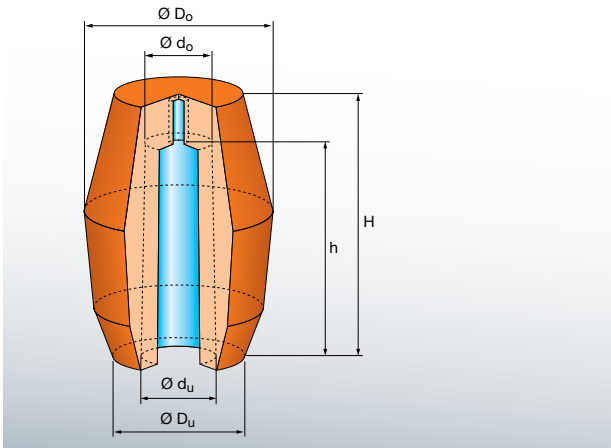

- Specially made for high-performance molding machines
- Riser geometry helps to prevent shadows of poorly compacted sand during molding and compression
- Small contact area if used with spring pins

EXACTCAST ADS are available in the following dimensions and packaging:

Type	Module	Riser capacity		Riser dimensions						Packaging
		exoth. cm	Volume dm ³	Weight kg	$\varnothing D_o$ mm	$\varnothing D_u$ mm	H mm	h mm	$\varnothing d_u$ mm	
ADS 5	0.75	0.01	0.06	50	28	57	50	16	13	4,356
ADS 12	0.85	0.01	0.10	60	40	60	50	21	18	2,520
ADS 16	1.20	0.02	0.16	70	40	85	66	21	18	1,620
ADS 19	0.95	0.03	0.20	60	40	80	70	25	20	2,520
ADS 20	1.20	0.03	0.18	78	36	100	85	21	18	1,520
ADS 27	1.30	0.04	0.27	78	50	100	85	25	23	1,216
ADS 32	1.30	0.05	0.33	78	50	100	92	27	24	1,216
ADS 61	1.70	0.09	0.61	87	60	107	97	36	32	960
ADS 85	1.90	0.12	0.85	104	65	135	110	40	35	560
ADS 86	1.90	0.12	0.85	100	70	135	110	40	35	560
ADS 111	2.20	0.16	1.11	122	90	122	100	50	40	392
ADS 133	2.50	0.19	1.34	140	100	140	120	50	40	288
ADS 164	2.20	0.24	1.64	122	90	122	100	60	50	392
ADS 193	2.80	0.28	1.93	140	100	140	125	58	48	288
ADS 237	3.20	0.34	2.38	145	95	145	120	65	55	220
ADS 425	3.50	0.59	4.13	143	112	150	127	80	76	168
ADS 540	4.20	0.75	5.25	170	110	210	175	80	70	140
ADS 550	4.20	0.78	5.46	193	128	210	175	80	70	120



EXACTCAST ADS (EX / EXF)

Technical & Ecological Advantages

- Suitable for gray iron, ductile iron, malleable iron and cast steel
- Improved yield thanks to lower liquid metal content
- Lower finishing costs by reducing the riser contact area and removal improved by using breaker cores
- Reduced fettling and blasting costs
- The slim riser geometry prevents poor compaction at the moment of molding or ramming
- Free of organic binders, low-emission, neutral CO₂ footprint
- Minimal riser residues in the used sand thanks to improved separability
- Available in fluorine-free (EXF) and low-fluorine (EX) formulations
- Reduced graphite degradation with fluorine-free mini-riser types
- By using fluorine-free risers, the sand system is free from fluorine contamination

Product Storage Conditions

- 9 months (if stored in dry conditions and intact original packaging)
- Protect from moisture
- Keep away from open flames and other ignition sources
- Read the Material Safety Data Sheet