



EXACTCAST OPTIMA KL (EX / EXF)

Silicate-bonded, highly exothermic, fiber-free mini-risers for iron and cast steel



Riser Types & Dimensions

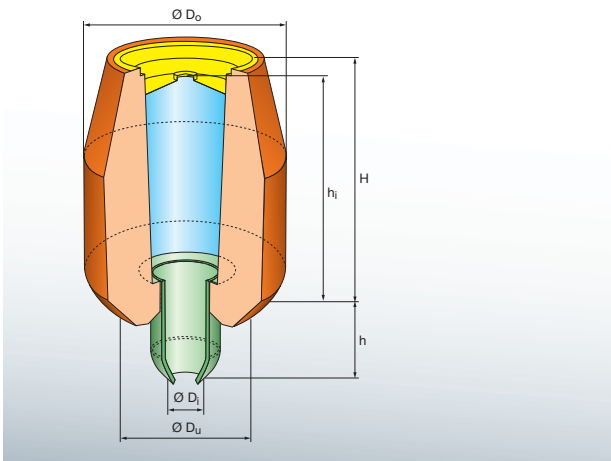

- Patented cap keeps inclusions and exothermic material out of the mold
- Exactly defined breaker edge makes breaker cores redundant
- No contact between casting and exothermic material

EXACTCAST OPTIMA KL are available in the following dimensions and packaging:

Type	Module	Riser capacity		Riser dimensions						Packaging
		exoth. cm	Volume dm ³	Weight kg	$\varnothing D_o$ mm	$\varnothing D_u$ mm	$\varnothing D_i$ mm	H mm	h mm	
KL 19	0.95	0.043	0.04	60	40	16	80	35	77	2,520
KL 27	1.30	0.055	0.30	78	50	16	100	35	97	1,216
KL 40	1.50	0.094	0.66	88	65	20	90	38	87	1,200
KL 61	1.60	0.155	1.08	84	50	20	122	36	119	1,088
KL 80	1.70	0.120	0.99	98	60	20	100	36	97	768
KL 86	1.80	0.164	1.15	98	55	20	128	36	125	768
KL 90	1.90	0.160	1.18	105	60	20	105	36	102	640
KL 111	2.10	0.190	1.33	118	66	20	120	36	117	480
KL 115	2.20	0.224	1.94	122	80	20	135	36	132	392
KL 193	2.70	0.299	2.09	134	88	30	140	36	137	336
KL 197	2.80	0.354	2.48	136	90	30	140	36	137	336
KL 237	3.10	0.312	2.18	136	88	30	145	36	142	336
KL 239	3.20	0.369	2.58	145	95	30	145	36	142	264
KL 430	3.50	0.399	2.79	150	90	30	155	35	151	220
KL 540	4.20	0.562	3.93	170	120	30	210	35	206	140



EXACTCAST OPTIMA KL (EX / EXF)

Technical & Ecological Advantages

- Suitable for gray iron, ductile iron, malleable metal and cast steel
- Very small contact area
- Ideally suited for high-pressure molding lines
- Minimizes fettling and blasting costs
- Customer-specific volumes possible by modifying the top
- Free of organic binders, low-emission
- Minimal riser residues in the used sand thanks to improved separability
- Available in fluorine-free (EXF) and low-fluorine (EX) formulations
- Reduced graphite degradation with fluorine-free mini-riser types
- By using fluorine-free risers, the sand system is free from fluorine contamination
- For use with spring pin or rigid pin
- Lid prevents formation of exothermic riser particles during compaction
- Also available in the 100% inorganic special variant with metal lid (special pin required)

Product Storage Conditions

- 9 months (if stored in dry conditions and intact original packaging)
- Protect from moisture
- Keep away from open flames and other ignition sources
- Read the Material Safety Data Sheet