

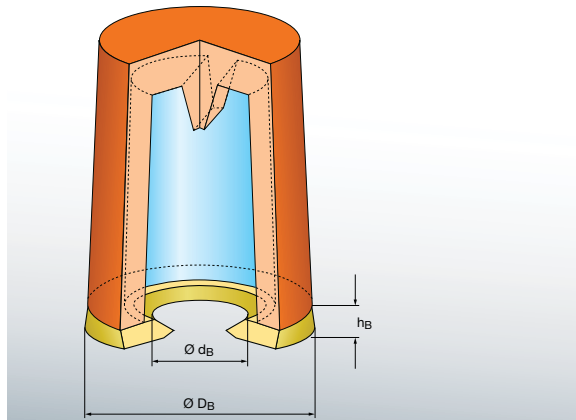

Breaker Cores for EXACTCAST KP

Riser Types & Dimensions



- The sand breaker core tapers the riser neck considerably
- Easy removal of the riser neck
- Reduced fettling costs
- Suitable for gray iron, ductile iron, malleable metal and cast steel

EXACTCAST KP insertable riser sleeves with breaker core are available in the following dimensions and packaging:

Type	Breaker core dimensions			Packaging pcs./ pal.
	$\varnothing D_B$ mm	$\varnothing d_B$ mm	h_B mm	
KP 3 / 5 W E 15	48	15	6	4,800
KP 3 / 5 W E 20	48	20	6	4,800
KP 3,5 / 5 W E 20	56	20	6	4,200
KP 4 / 5 W E 25	63	25	8	3,600
KP 4 / 7 W E 25	66	25	8	3,024
KP 4 / 9,5 W E 25	66	25	8	1,944
KP 5 / 8 W E 30	76	30	8	1,804
KP 6 / 9 W E 30	84	30	8	1,080
KP 7 / 10 W E 35	98	35	10	768
KP 8 / 11 W E 40	107	40	10	576
KP 9 / 12 W E 45	120	45	10	448
KP 10 / 13 W E 50	132	50	10	308
KP 12 / 15 W E 60	160	60	12	160

Product Storage Conditions

- 9 months (if stored in dry conditions and intact original packaging)
- Protect from moisture
- Keep away from open flames and other ignition sources
- Read the Material Safety Data Sheet

ASK Chemicals GmbH | Reisholzstr. 16 - 18 | 40721 Hilden, Germany | Phone: +49 211 71103-0 | info@ask-chemicals.com | www.ask-chemicals.com

The following marks are registered by ASK Chemicals GmbH, ASK Chemicals Metallurgy GmbH or ASK Chemicals LP in one or more countries: ALPHASET, ASKOBOND, ASKRONING, ASKURAN, BERANOL, BETASET, CERAMCOTE, CHEM-REZ, DENODUL, DISPERSIT, EXACTCALC, EXACTCAST, EXACTFLO, ECOCURE, ECOPART, GERMALLOY, INFORM, INOBAKE, INOSOLVE, INOTEC, ISOCURE, ISO-FAST, ISOMAX, ISOSEAL, ISOVENTS, LINO-CURE, MAGNASET, MIRATEC, NOVACURE, NOVANOL, NOVASET, OPTIGRAN, OPTINOC, PEP SET, REMMOS, SMW-INSERT, SOLITEC, STA-HOT, UDICELL, VEINO, VEINO ULTRA, VELVACOAT, ZIP CLEAN, ZIP SLIP.