



EXACTCAST KIM-QM (EX / EXF)

Cold Box bonded, highly exothermic, fiber-free, riser sleeves for iron and cast steel



Riser Types & Dimensions

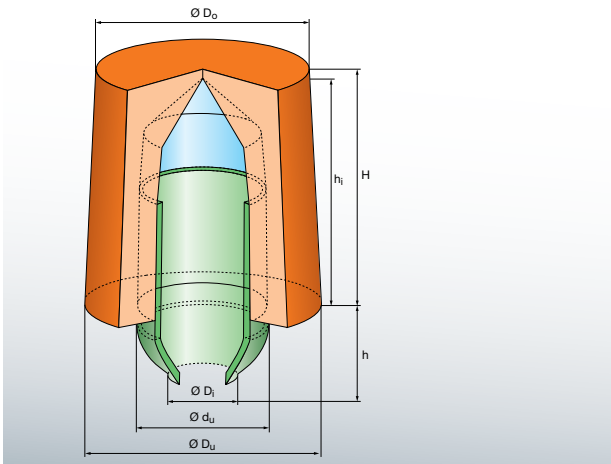

- Available in fluorine-free (EXF) and low-fluorine (EX) formulations
- Ideally suited for high-pressure molding lines
- Very small contact area
- Extremely lightweight

EXACTCAST KIM-QM are available in the following dimensions and packaging:

Type	Module	Riser capacity	Riser dimensions							Packaging
			exoth. cm	Volume dm ³	Ø D _o mm	Ø D _u mm	Ø D _i mm	Ø d _u mm	H mm	
KIM 4/7 Q 15 M	1.3	0.032	58.5	62.5	15	25	73	68	25	1.416
KIM 4/95 Q 15 M	1.3	0.040	59.0	63.0	15	25	97	92	25	1.416
KIM 5/8 Q 20 M	1.6	0.080	69.5	74.0	20	40	80	75	35	1.008
KIM 5/10 Q 20 M	1.7	0.100	69.5	74.0	20	40	101	95	35	1.008
KIM 6/9 Q 25 M	1.8	0.150	75.5	80.5	25	50	92	87	35	792
KIM 6/12 Q 25 M	1.9	0.194	72.5	80.5	25	50	116	111	35	–
KIM 7/10 Q 30 M	2.1	0.225	89.0	94.5	30	60	99.5	94	35	576
KIM 8/11 Q 30 M	2.3	0.251	96.0	102.0	30	60	108	103	35	480
KIM 9/12 Q 40 M	2.6	0.474	109.5	115.0	40	80	120	115	35	–
KIM 10/13 Q 40 M	2.9	0.540	119.0	127.5	40	80	133	128	35	312
KIM 12/15 Q 50 M	3.3	0.818	147.0	154.5	50	100	150	145	35	–



EXACTCAST KIM-QM (EX / EXF)

Technical & Ecological Advantages

- Exactly defined breaker edge makes breaker cores redundant
- Fix pins
- No contact between casting and exothermic material
- Minimizes fettling and blasting costs
- Excellent dimensional accuracy, ideal for insertion
- Additional insulation effect
- Reduced graphite degradation with fluorine-free mini-riser types
- By using fluorine-free risers, the sand system is free from fluorine contamination

Product Storage Conditions

- 36 months (if stored in dry conditions and intact original packaging)
- Protect from moisture
- Keep away from open flames and other ignition sources
- Read the Material Safety Data Sheet